

# Agilent EEsof EDA Advanced Design System

**For Designs that Live Up to Your Dreams**



**Agilent Technologies**



*"We were pleasantly surprised to learn that Agilent EEsof EDA offers affordable choices for growing companies like us. They set the standard for high-frequency design software and have the broadest range of simulation capabilities. I'm confident that we have chosen a toolset that can expand with us as we grow."*

**Steven J. Bennett**  
Vice President of Research and Development, Unity Wireless Systems

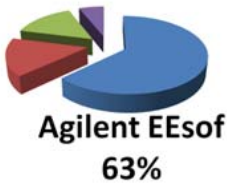

In Gary Smith EDA's 2009 market share report, Agilent EEsof was recognized as the leading provider of RF Design and Simulation tools.

## For designs that live up to your dreams, choose software that lives up to your designs

As technology and competition accelerate, so do the challenges of getting to market first, with better, smaller, and faster products. Today, it is critical for engineers to be productive and effective. Efficiently exploring different design possibilities requires powerful tools and methodologies.

Agilent understands these challenges first-hand. Our diverse electronic products and test and measurement businesses include designers of RF and microwave semiconductor products such as duplexers, filters, mixers, and RFICs. Our own fabrication facilities include Si and GaAs processes for manufacturing circuits and components such as mixers, attenuators, prescalers, switches, and power amplifier ICs – all used extensively in today's sophisticated communications products.

Our EDA business grew out of an internal need to improve the design process for RF and microwave test instrumentation. The business quickly grew to division status, with a long history of innovation that continues today, including many patented technologies and current patents pending.

With the introduction of the Touchstone linear simulator more than 20 years ago, Agilent EEsof EDA has led the development of new high-frequency EDA technologies such as Harmonic Balance and Circuit Envelope simulators, RF/analog/baseband co-simulation and behavioral

models. It is technology that has proven its robustness and lasting value over time.

### Most popular high-frequency design software

Advanced Design System (ADS) is the industry leader in high-frequency design. It supports system and RF design engineers developing all types of RF designs, from simple to the most complex, from RF/microwave modules to integrated MMICs for communications and aerospace/defense applications. With a complete set of simulation technologies ranging from frequency and time-domain circuit simulation to electromagnetic field simulation, ADS lets designers fully characterize and optimize designs. The single, integrated design environment provides system and circuit simulators, along with schematic capture, layout, and verification capability – eliminating the stops and starts associated with changing design tools mid-cycle.

Agilent EEsof EDA offers a wide variety of flexible plans to work within your budget. Time-based licenses and limited-term packages are available to get you the tools you need today. As your design needs grow, you can add simulators, models, and libraries as you require them.

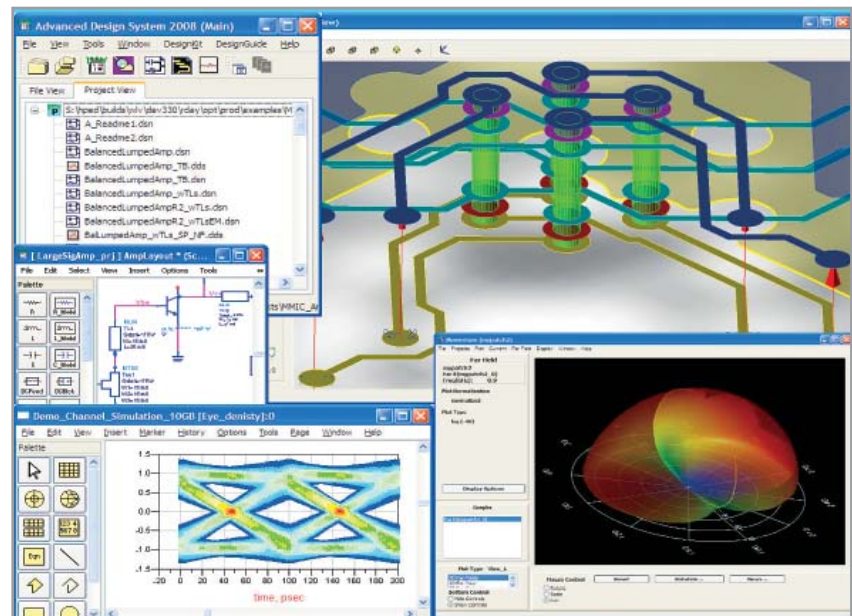

## More focus on design – less on learning

Time-to-market pressures often don't accommodate learning a new software package. To help designers get to first-cut design results, ADS supplies over 300 examples or start from templates. ADS supplies over 300 examples, accessed through a powerful search engine. Each example gives instructions for using ADS, enabling you to focus on the design, and not on the design tool.

### Data display for the big picture

If your simulation results do not allow you to see at a glance how your design is performing, you're losing productivity. The strong data analysis and display technology in ADS lets you view results in the many ways you may want to see them. Post processing capabilities

let you manipulate data using custom expressions, view data on different plots, and change specifications, all without re-simulating.

### Design Libraries for easier wireless design

For cutting-edge wireless design, ADS Design Libraries help get emerging wireless products to market faster. By building the latest signal formats into ADS, you can spend your time on new design ideas, not on researching the standards. Design Libraries contain pre-configured schematics, data displays, and test benches to help you verify designs against measurements defined in the wireless standards specifications.

### DesignGuides for expert help

Agilent EEsof EDA has more than a dozen industry experts using their experience and best practices to create application-oriented ADS DesignGuides. DesignGuides make the job of circuit design easier, faster, and more consistent with wizards, pre-configured set-ups and displays, and step-by-step instructions. Complete design applications such as amplifiers, filters, mixers, microstrip circuits, RF systems, Bluetooth, and ultra-wideband designs, to name just a few, give you easy access to the power of ADS without taking time to learn from scratch.

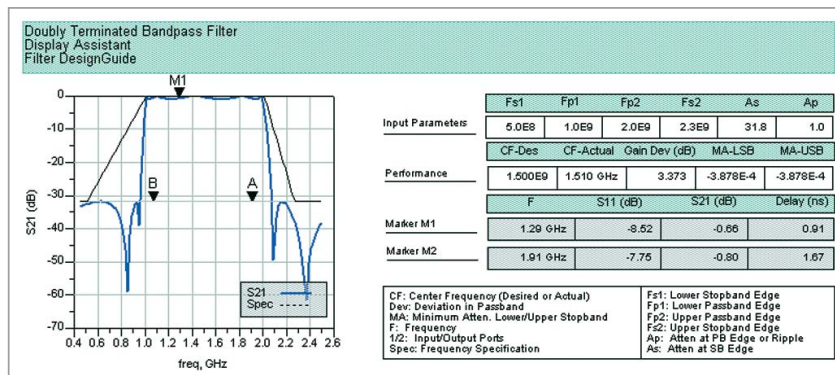

DesignGuides and templates in ADS make displaying simulation results easy.



The ADS optimization cockpit provides an interactive environment with multiple optimization variables, interactive tuning and progress controls. Achieve the best performance while gaining design insight of the optimized variables versus the goals.

*"I collaborate with Agilent EEsof EDA because they have the largest customer base to potentially benefit from my expertise. The open architecture of the ADS platform makes it easy for application specialists like me to develop DesignGuides. The time I put into a DesignGuide is time saved in engineering cycles."*

**Dr. Michael Jensen**  
 Professor of Electrical Engineering, Brigham Young University and Vice President of AJ Design Group



# The widest choice in models – from Process Design Kits to custom extraction



“ADS is an important toolset to support. It has the widest usage among our customer base and within TriQuint.”

**Eli Reese**  
Director of  
Design Engineering at  
TriQuint Semiconductor  
in Richardson, Texas.

## Design kits for foundry process compatibility

Agilent works with top foundries around the world to develop and support process design kits for RFIC and MMIC design in ADS. Kits are maintained by the foundry, so you can be sure they provide the most accurate and up-to-date models for their latest process, as well as the most comprehensive design automation features.

## High-quality models for accuracy

Accurate models are a prerequisite for any successful design flow. Without good models, designers can't make progress or have confidence in their simulation results.

ADS has models for every microwave and RF design application:

- RF System models provide gain blocks, mixers, filters, modulators and demodulators, PLL components, and passive elements for accurate and easy system design.
- All the major component vendors provide up-to-date component libraries specifically for ADS.
- Component libraries have over 100,000 parts. Many contain auto-layout capabilities for creating a layout directly from schematic for design rule checking or planar EM simulation.
- Design Libraries contain models for the latest communication standard modulation formats, including 3GPP LTE, HSPA, Mobile/Fixed WiMAX™, DTMB, CMMB, WVAN, CDMA, GSM, DTV, 802.11n, TD-SCDMA, WLAN, W-CDMA, CDMA2000/1xEV, EDGE, WiMedia.

Several options allow you to develop customized models that meet your specific device and product requirements:

- Advanced Model Composer, based on a patented technology, uses EM simulation to create accurate passive models that have the simulation speed advantages of analytical models.
- Verification Model Extractor creates system-level behavioral models from device-level circuit designs for faster system-level verification.
- Analog Model Development Kit generates user-defined circuit and system models for integrating proprietary behavioral models.
- Verilog-A compiler allows the simulation of custom device models and behavioral models in Verilog-A format.

Agilent also provides modeling systems to develop accurate device model extractions.



# Industry-leading simulation technology – circuit to system, simple to complex

## Simulator technology handles size, complexity, with ease

Designing circuits for different functional blocks often requires an array of simulation technologies. ADS offers the most complete set of simulation technologies available today in a single software package. Combined, they enable you to fully characterize and optimize designs under varied conditions without simulator-imposed limitations on accuracy, depth, or detail. The result is a design that can exceed performance requirements and be manufactured at high volumes.

## Simulator highlights:

- For system-level simulation, Agilent Ptolemy is the only commercially available timed synchronous data flow simulator. It is used at the behavioral level to simulate baseband circuits as well as analog and RF circuits. Use it to observe circuit performance via bit error rate and constellation diagrams. For more realism, Ptolemy can co-simulate with the analog and RF simulators, allowing you to see the effects that circuit-level blocks have on system-level results, for a true mixed-signal analysis.

- When it was introduced in the early 1980s, Harmonic Balance was the first commercially available simulator of its kind. Over time, it has developed into the most advanced frequency-domain simulator for fast analysis of nonlinear circuits. Today, it can handle large-scale ICs with thousands of transistors. It also simulates digital frequency-divider circuits using the Transient Assisted Harmonic Balance capability.
- Circuit Envelope is a patented ADS innovation that enables accurate analysis of time-varying carriers directly in the frequency domain. Only Circuit Envelope simulates time-varying signal response at the system level, allowing

direct and easy optimization of circuit performance. Key applications include modulator/ demodulator response, synthesizer hopping analysis, phase-lock-loop-based automatic frequency control response, oscillator stability and warm up, and automatic gain control/phase-lock-loop response to complex signals.

- The RF System simulator contains a unique RF system budget analysis feature that lets you examine more than 40 system measurements such as third-order intercept, 1dBc, and noise figure for each component in the high-level system.

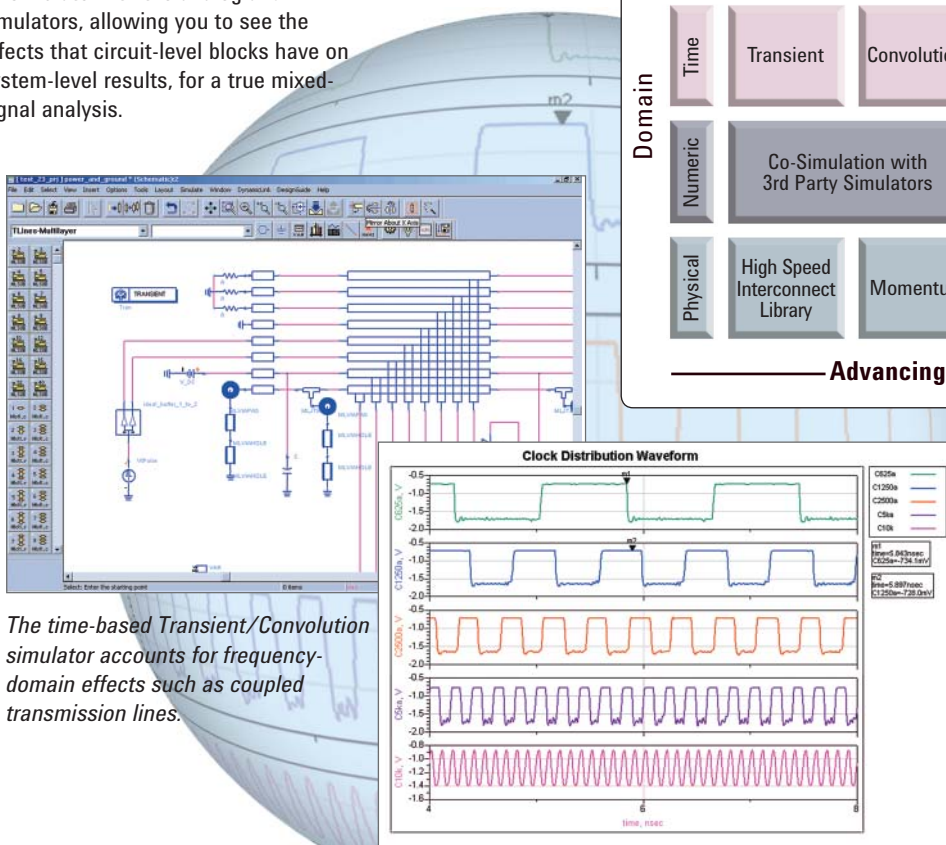

The time-based Transient/Convolution simulator accounts for frequency-domain effects such as coupled transmission lines.

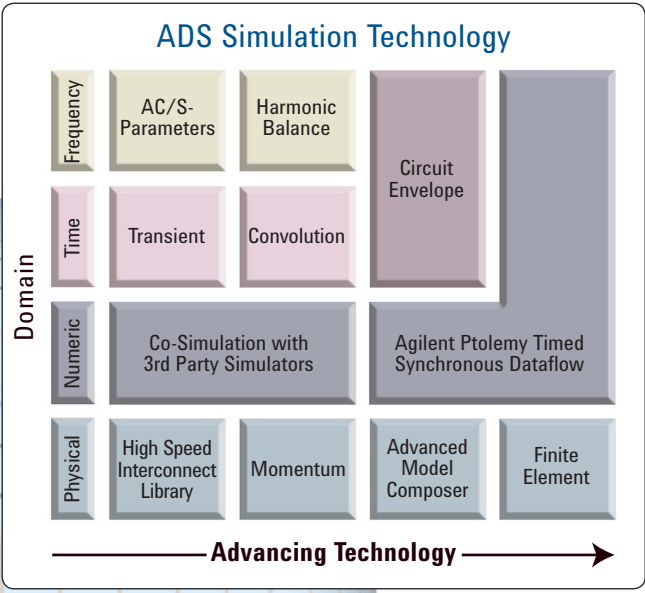

## From the spark of an idea to a verified design –

Agilent EEsof EDA is committed to providing the most complete design flow. Where gaps exist that give designers pain and take up their time, we round out our product line and solutions to bridge them.

### Physical design predicts performance

Accurate implementation of physical design is important for predicting hardware performance. ADS includes a comprehensive physical design environment specifically geared for high-frequency layout design and verification. It hosts a number of capabilities such as design synchronization with schematic, a physical connectivity engine, integrated EM simulators, and a design rule checker (DRC). Layout allows designers to fully characterize artwork and improves the ability to catch errors prior to production. High-frequency designs can even be started in Layout and back-annotated to schematic for further analysis.

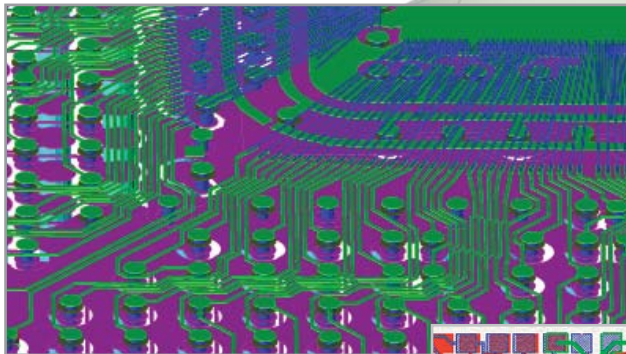

ADS Layout information is combined with the Momentum substrate definition to produce a 3D spatial representation of circuit geometries.

### Physical Connectivity Engine

When it comes to high-frequency design, traditional LVS tools often limit interconnect options to simple traces. Agilent's Physical Connectivity Engine lets you use any custom shape to build interconnects. The engine runs in the background and extracts interconnect information from traces, paths, vias, and custom polygons, in real time, allowing you to perform a number of interconnect checks without launching a separate utility. The Physical Connectivity Engine also allows you to verify real-time-connectivity graphically on your layout, providing a true representation of interconnects. Better interconnect representations reduce design uncertainty before prototyping, so you can be confident that what you design in schematic is what you represent in layout.

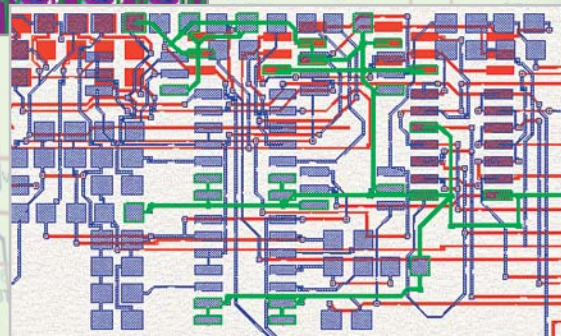

The Physical Connectivity Engine check connectivity feature allows you to highlight any trace or interconnect. It then highlights all overlapping metal.

### Momentum & FEM Simulator for EM Analysis

Both Agilent's Momentum and Finite Element Method (FEM) simulators are fully integrated with the ADS layout environment. Momentum is the leading 3D planar electromagnetic (EM) simulator used for multi-layer IC and PC Board analysis. The FEM simulator is based on full 3D EM technology that can handle 3D arbitrary shaped structures such as connectors, conical shape vias and solder balls/bumps where z-dimensional changes appear in the structure. Both simulators generate accurate EM models that can be used directly with ADS circuit simulators.

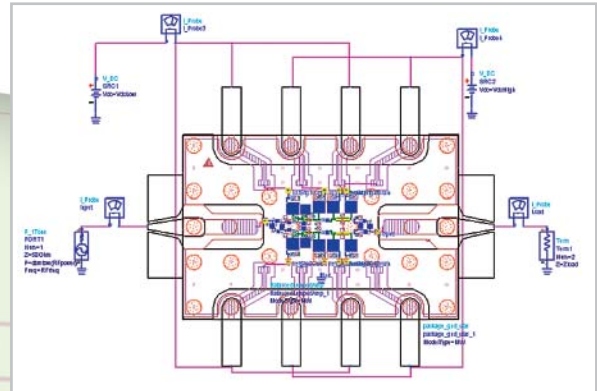

Co-simulation with Layout Components allows you to incorporate layout artwork in the schematic environment to enable concurrent analysis of circuit performance along with critical physical effects.



## – with no break in the flow

### Connected Solutions

Design verification using today's complex communications signal formats is a challenge. Designs can be analyzed early in simulation, and they can be verified later, after all of the hardware returns from fabrication – but designers don't have the luxury of waiting for all of the hardware. They need an intermediate level of verification to cut overall design time and reduce risk.

Agilent's connected solutions allow verification very early in the prototyping cycle for applications ranging from emerging wireless communications products to aerospace/defense by integrating ADS with Agilent test instruments such as signal generators and signal analyzers to enable new design and verification capabilities. This unique combination allows the sharing of signals, measurements, algorithms, and data seamlessly between the virtual software and physical hardware domains. Designers use this linkage to simulate and evaluate design trade-offs and what-ifs and then turn the simulated signal into an RF test signal on the bench for hardware test. Conversely, designers can take the measured output signal from the DUT and bring it into ADS for additional analysis in the simulation environment.

### Design flow integration – partners for complete success

At Agilent EEsof EDA we align with key EDA vendors and frameworks to provide enhanced solutions that complement your investment. The open and flexible ADS environment ensures that a wide range of design flows is supported. For example, if your design flow is based on a Cadence, Mentor or Zuken flow, Agilent EEsof EDA supports these frameworks with integration products using industry-standard formats. Our expanding list of partners goes well beyond standard relationships and is part of an ongoing effort to provide best-in-class tools and technology that work the way you work best—in an integrated environment.



### New X-Parameter Generator

X-parameter models are fast, cascadable, nonlinear behavioral models that accurately account for frequency mixing and impedance mismatch. X-parameters fulfill a long standing need from the high-frequency design community for nonlinear behavioral models that can be created from measurement or simulation with the same speed and convenience as the well known linear S-parameters. The X-Parameter Generator enables MMIC, RF-SIP and RF module design houses to provide their customers with an accurate, pre-prototype model of their nonlinear devices (e.g. power amplifiers, front-end modules and transceivers) to further enable concurrent design and secure early design wins.

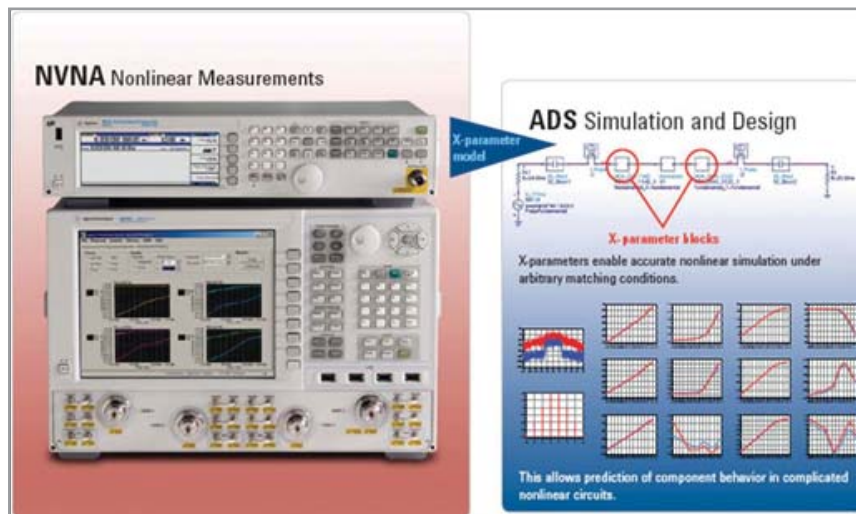

Agilent's X-parameters\* represent a new category of nonlinear network parameters for high-frequency design. They are applicable to both large-signal and small-signal conditions, and for linear and nonlinear components.

*"Agilent's design software and test hardware accelerates our design verification, giving us the confidence to begin prototyping"*

**Eric Hansen**  
President and CEO of  
Innovative Wireless  
Technologies

# Application Areas

## – from RF to microwave, from circuit to system,

### Microwave/MMIC design

Reduce costs and get to market fast, and first. This is the challenge that MMIC designers face. ADS rises to this challenge, making MMIC design faster and easier than ever before. ADS supports a complete, front-to-back flow by incorporating Layout and all of the ADS simulation technologies (system, circuit, and electromagnetic) in a single, integrated design flow. All of today's leading GaAs foundries actively maintain component design kits that support the powerful ADS simulation technologies.

In microwave circuit design, the circuit and physical designs must be closely linked. ADS allows you to start a MMIC design in either the layout or schematic environment. The design synchronization engine controls and tracks design updates and supports multiple design synchronization modes to match your methodology.

The ADS Layout components feature adds a new dimension to MMIC design. You can bring a layout directly into the schematic environment to give you access to EM simulators within your circuit design. Or, you can bring in a DUT board – characterized by network analyzer measurements or by EM simulation – for concurrent modeling of the design while accounting for board or packaging effects.

### Signal integrity/ high-speed digital design

Signal integrity is a major concern for engineers of high-data-rate designs, such as Infiniband, PCI Express, and RapidIO. Meeting the demand for increasingly fast circuits with high clock speeds is a constant challenge. High-frequency analog effects such as reflection, cross talk, ground bounce, and propagation delays through interconnects adversely affect signal quality and timing performance.

ADS has the right simulation tools and libraries, including a multi-layer interconnect library that enables you to accurately model and analyze high-speed interconnect problems before fabrication, resulting in lower development costs and faster time to market.

### RFIC design

As today's wireless and wireline applications increase in frequency and speed, RFIC design engineers need access to accurate and efficient high-frequency simulation tools. Shorter product life-cycles and global competition continue to add pressure for quality product designs. Agilent EEs of EDA has the most comprehensive set of simulation tools, models, and verification features to increase the robustness of your RFIC designs.

If your designs are based on the Cadence flow, you can access Agilent's powerful frequency-domain simulation technologies directly from within the Cadence environment using Agilent's GoldenGate. Circuit netlists from the Cadence environment can also be brought into ADS for analysis using Dynamic Link. Either way, you've got the power to efficiently design RFICs with high performance and yield for capitalizing on market opportunities.

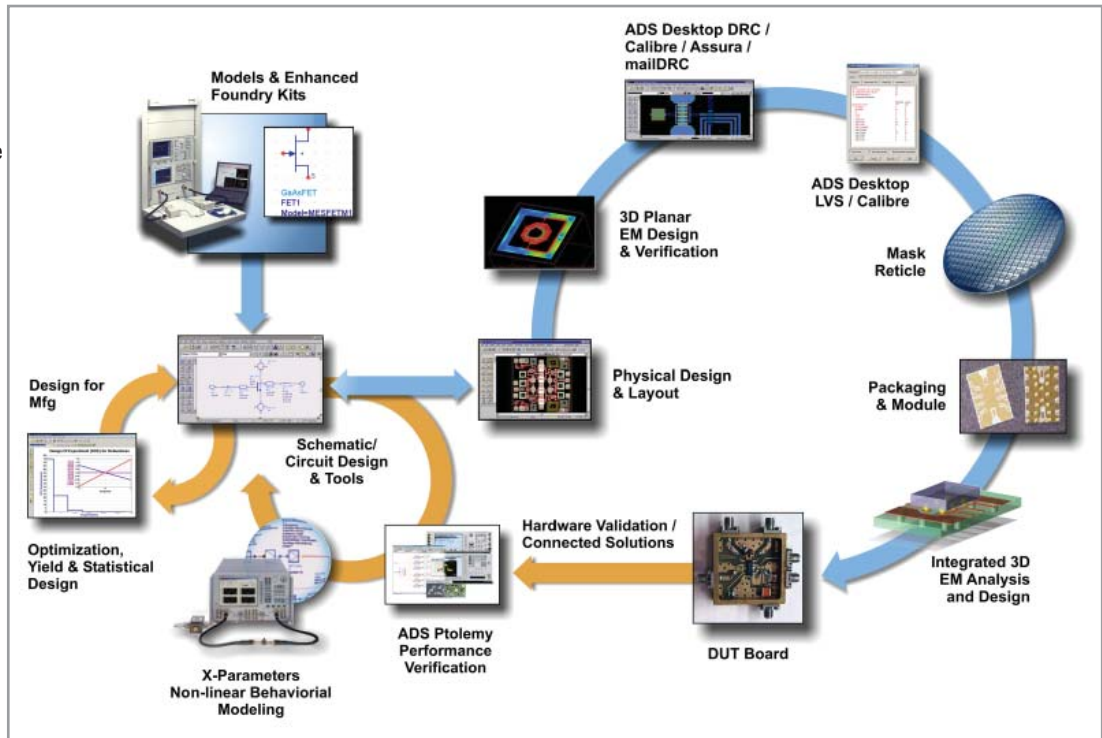

*The Complete MMIC ADS Desktop Design Flow enable front-to-back design and simulation to physical design, verification and manufacturing.*



# from board to package to RFIC – ADS is the tool of choice

## Communications system design

Today, the complexities of system design are greater than ever. Designers working with recent and emerging wireless standards such as 3GPP LTE, HSPA, Mobile/Fixed WiMAX™, DTMB, CMMB, WVAN, CDMA, GSM, DTV, 802.11n, TD-SCDMA, WLAN, W-CDMA, CDMA2000/1xEV, EDGE, WiMedia, need to reduce design turns and get to market quickly with a complete system that satisfies the needs of RF/analog and baseband applications. Aerospace/defense industry designers also need quick design turns and rapid design verification when specifications are incomplete and measurements are highly specialized.

Wireless communications product system designs must be partitioned into their baseband and RF portions. For the RF portion, ADS provides more behavioral models than any other EDA vendor – more than 1800 models in all. ADS design and model libraries are preconfigured for simulation and contain the most complete set of measurements available. When additional measurements are required, Connected Solutions fills the gap with signal generation, sharing, and analysis via instrument-software links.

In aerospace/defense, Agilent's connected solutions are particularly useful for extending the standard measurements provided by Agilent's test instruments by combining them with ADS and its extensive library of behavioral models.

## RF Board design

Today's high-frequency RF board designer wants few board re-spins and high-yield designs. The integrated system, circuit, and EM simulators, Layout, and powerful optimizers in ADS help increase productivity and efficiency, validating your high-yield designs prior to manufacturing. Our focus on design flow integration means that ADS works with your other framework integration products, such as Mentor, Cadence and Zuken.

Integration also means that the ADS Layout tool is linked to the schematic environment. This back-annotating link, coupled with our integrated EM simulator, allows you to account for physical effects that could significantly affect design performance. The Physical Connectivity Engine detects wiring information that is so important to a correct layout, and feeds it to the interconnect checking features in ADS for an accurate representation of layout interconnects.

A growing list of up-to-date component libraries is available for ADS RF board design. Agilent, component vendors, and modeling companies regularly update these libraries, and we provide download access to them via the Agilent EEsof EDA web site.

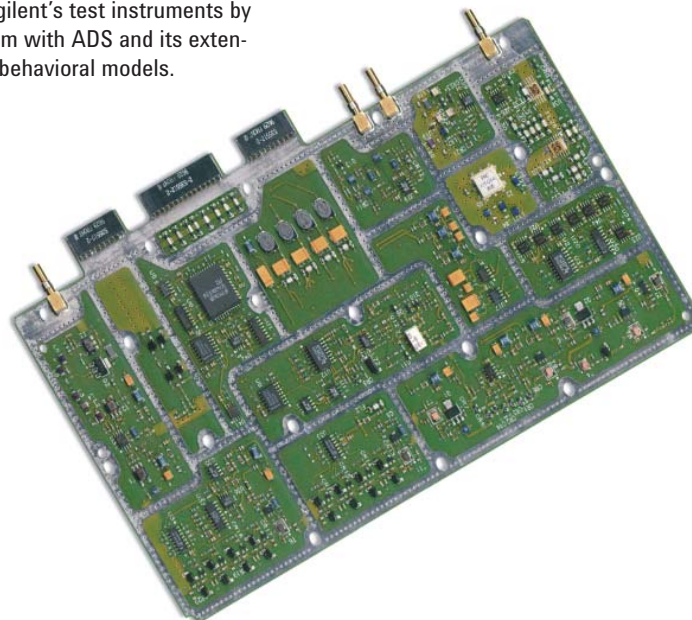

An ever growing list of component vendors provide libraries for ADS. (Several of these are offered by Modelithics, Inc.)

- Agilent
- Analog Devices
- Altera
- Amerian Technical Ceramics(ATC)
- Astra MTL
- AVX
- Banpil Photonics
- Coilcraft
- Cree
- DT Microcircuits - LTCC
- Dupont - LTCC
- Epcos
- Excelics
- Freescale
- Hittite Microwave
- HRL Laboratories, LLC
- Huber+Suhner AG
- Infineon
- Johanson Technologies
- KOA Speer
- Mitsubishi
- Murata
- MWT
- NEC
- NXP
- On Semiconductors
- Panasonic
- Philips
- Polyfet
- Presidio Components Inc.
- Samsung
- Samtec
- SAMYOUNG
- Skyworks
- Taiyo Yuden
- Temwell
- TDK
- Thin Film Technology (TFT)
- Toko
- Toshiba
- Transcom
- Vishay

# Getting the most from ADS

## World-class support

Agilent Technologies is committed to customer satisfaction. We are dedicated to providing the right software, support, and consulting solutions to increase your engineering productivity and advance your long-term success. Whether you are a novice or experienced user, Agilent EEsof EDA's customer support offerings are designed to help you every step

of the way. They include software and user manual updates via download or on CD-ROM, worldwide technical support via telephone, fax, e-mail, and the worldwide web.

In a world where not only your product goes international, but often your design team is also distributed across continents,

you need to ensure that support will be there when and where you need it. Agilent EEsof EDA has dedicated support engineers in many countries to provide you with local language support, including English, Japanese, Korean, Mandarin, French, German, and Dutch. Phone support is available Monday through Friday, worldwide.

## Knowledge Center

The Agilent EEsof EDA support web site, featuring the Agilent EEsof Knowledge Center, is an around-the-clock resource for designers. The Knowledge Center contains thousands of support documents and hundreds of downloadable examples created by support engineers to supplement the ADS application examples and documentation.

In the Knowledge Center, Maintenance Service Releases – with updates to previously released software versions – are available for download. A tracking feature allows you to submit and manage your support cases and related defect and enhancement requests. A robust search function lets you quickly find available solutions and sort through them by date,

popularity, or user ratings. The Knowledge Center also contains product discussion forums where you can converse with other users, support engineers, and product developers, along with recorded Technical Info Sessions and introductory e-Learning Short Courses.

The screenshot displays the Agilent EEsof EDA Knowledge Center website. The page header includes the Agilent Technologies logo and navigation links. The main content area is titled "Agilent EEsof EDA Technical Support & Knowledge Center" and features a search bar, a search example, and a list of support resources. A circular inset image shows a woman wearing a headset, looking at a computer screen, representing customer support.

**Agilent Technologies**  
Agilent Home > Agilent EEsof EDA Design & Simulation Software > [Talk with an Expert](#)

### Agilent EEsof EDA Technical Support & Knowledge Center

Whether you are a novice or experienced user, Agilent EEsof EDA's support and services offerings are designed to help you every step of the way.

Use the Knowledge Center's Technical Support Documents & Examples, Product Documentation, Forums and Software Download resources below to help answer your questions.

**Search Technical Support and Product Documentation**

**Search Example:**  
EMPro would yield EMPro or EMPower  
ADS quotes to search for a string like "ADS 2009"  
[View Search Results](#)

Note: Some content may require a login to access the documentation.

<b>Support Policy</b>	<ul style="list-style-type: none"><li><a href="#">Agilent EEsof EDA Support Policy</a></li></ul>
<b>Contact Support</b>	<ul style="list-style-type: none"><li><a href="#">Log A Support Case in My Knowledge Center</a></li><li><a href="#">Regional Phone Numbers and Email Addresses</a></li></ul>
<b>Technical Resources</b>	<ul style="list-style-type: none"><li><a href="#">Technical Support Documents &amp; Examples</a></li><li><a href="#">Product Documentation</a></li><li><a href="#">Frequently Asked Questions (FAQs)</a></li><li><a href="#">Video Central</a></li><li><a href="#">Training Course Services</a></li></ul>
<b>Software Downloads &amp; Licensing</b>	<ul style="list-style-type: none"><li><a href="#">ADS</a></li><li><a href="#">EMPro</a></li><li><a href="#">Genesys</a></li><li><a href="#">GoldenGate</a></li><li><a href="#">IC-CAP</a></li><li><a href="#">SystemVue</a></li><li><a href="#">Request a License</a></li><li><a href="#">Licensing Tables</a></li><li><a href="#">FLEXnet Licenses</a></li><li><a href="#">Software Versus Operating Systems</a></li></ul> <p><small>Note: Hotfixes and SD from the product links product version release patches.</small></p>
<b>Discussion Forums</b>	<ul style="list-style-type: none"><li><a href="#">LinkedIn User Groups</a></li><li><a href="#">Agilent ADS User</a></li></ul>

**Products**

- Advanced Design System (ADS)
- EMPro 3D EM Simulation Software
- Genesys RF & Microwave Design Software
- GoldenGate RFIC Simulation Software
- Momentum 3D Planar EM Simulator
- SystemVue ESL Software

**Design Flows**

- MMIC Design
- High Speed Digital Design
- Electronic System-Level (ESL) Design
- RF Circuit Design (Connected Solutions)
- RFIC Design
- RF & Microwave Board Design
- RF SiP & RF Module Design
- Device Modeling

**Support & Resources**

- Knowledge Center
- Foundries, Component Vendors & More
- University Educational Support Programs
- YouTube Video Library
- Read Our Newsletter
- E-mail Agilent EEsof EDA

**Featured Links**

<a href="#">Parameters*</a>	<a href="#">MMIC/RF Moduls Design</a>	<a href="#">EM Insight Series</a>
Breakthrough nonlinear network parameters for high-frequency design	ADS 2009 Update 1 -- Complete MMICADS Desktop Design Flow	EM simulation application examples solving real-world design solutions

## – with support, training, services

### Achieve business results faster with help from the experts

Every design team's flow has aspects that are unique. To save time and get individual attention focused on your particular design needs, take advantage of Agilent EEsof EDA's consulting services. We offer complete consulting in MMIC, RFIC, RF board/module, or system-level design.

- Device Modeling – We can quickly characterize and extract industry-standard models for your device, and then (optionally) provide test structure and device layout design services.
- Process Design Kits – Let us create or extend your custom PDK elements or libraries.
- Connected Solutions – Get start-up training in simulation plus instrumentation set-up for X-parameters, 3G, LTE.
- Simulation Assistance – Eliminate trial and error. Get expert coaching and learn best practices for complex circuits or systems.
- Design Process Consulting – Let us perform an analysis of your design flow and make recommendations that will save you time and money.

### Training

Having a good working knowledge of your EDA software can save precious time in the design cycle. Increased productivity and added expertise can contribute directly to your job satisfaction and to your company's bottom line.

Agilent EEsof EDA training offers a full range of classroom courses, as well as live and self-paced e-learning courses that teach the use of EDA software in a wide variety of applications. Live classes are conducted by experienced design engineers and focus on in-depth software operation and design examples, as well as covering introductory and advanced microwave, RF, System, and signal integrity design techniques. Self-paced e-learning courses allow you to set your own timetable. If you can't travel to a regularly scheduled class and have a group of designers who can benefit from a common class, your field sales representative can arrange an on-site class.



*"I really appreciate the Agilent EEsof EDA training class. The presentation of ADS capabilities, such as how to simulate an entire communication link and integrate RF with Ptolemy, is excellent."*

**Peter Denney**  
RF/Antenna Engineer,  
Harris Corporation



# Get what you need today, with an eye to what you'll need tomorrow

Extensible design suites let you begin with a front-to-back solution that fits your budget, adding capabilities as you need them. ADS products range from economical foundation toolsets to advanced,

comprehensive suites. Time-based licenses and limited-term packages also are available to give you the tools you need just when you need them.

## ADS Product Structure

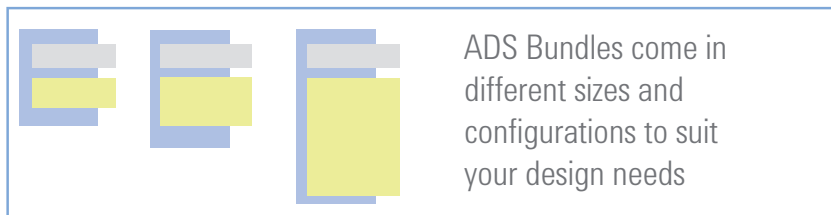
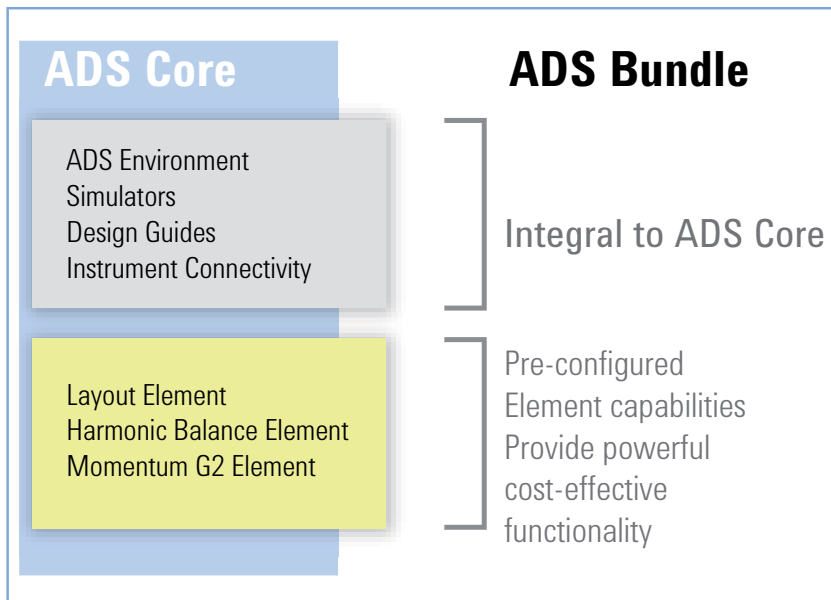

The flexible product structure of ADS lets you begin with pre-configured bundles and add capabilities as you need them.

[www.agilent.com](http://www.agilent.com)  
[www.agilent.com/find/ads](http://www.agilent.com/find/ads)

For more information on Agilent Technologies' products, applications or services, please contact your local Agilent office. The complete list is available at:

[www.agilent.com/find/contactus](http://www.agilent.com/find/contactus)

### Americas

Canada	(877) 894 4414
Brazil	(11) 4197 3500
Mexico	01800 5064 800
United States	(800) 829 4444

### Asia Pacific

Australia	1 800 629 485
China	800 810 0189
Hong Kong	800 938 693
India	1 800 112 929
Japan	0120 (421) 345
Korea	080 769 0800
Malaysia	1 800 888 848
Singapore	1 800 375 8100
Taiwan	0800 047 866
Other AP Countries	(65) 375 8100

### Europe & Middle East

Belgium	32 (0) 2 404 93 40
Denmark	45 70 13 15 15
Finland	358 (0) 10 855 2100
France	0825 010 700*
	*0.125 €/minute
Germany	49 (0) 7031 464 6333
Ireland	1890 924 204
Israel	972-3-9288-504/544
Italy	39 02 92 60 8484
Netherlands	31 (0) 20 547 2111
Spain	34 (91) 631 3300
Sweden	0200-88 22 55
United Kingdom	44 (0) 118 9276201

For other unlisted Countries:

[www.agilent.com/find/contactus](http://www.agilent.com/find/contactus)

Revised: October 14, 2010

Product specifications and descriptions in this document subject to change without notice.

© Agilent Technologies, Inc. 2001-2010  
 Printed in USA, November 9, 2010  
 5988-3326EN